

Learner Name:	
Learner Email Address:	
Date Training Commenced:	



Australia Wide Forklift Training Centre Pty Ltd
(also trading as Advanced Heavy Vehicle Driver Training Centre)
ABN: 871 0929 9185 RTO No: 21784

TLILIC0004

Licence to operate an order picking forklift truck



LEARNER GUIDE

Table of Contents

1.1 Introduction	4
1.1.1 What is an Order Picking Forklift?	4
1.1.2 Parts of an Order Picking Forklift	5
1.1.3 High Risk Work Licence Requirements	5
1.2 Plan Work	6
1.2.1 Work Health and Safety Requirements	7
1.2.2 Duty of Care	7
1.3 Manage Hazards and Risks	9
1.3.1 Consulting with Other Workers about Hazards and Risks	9
1.3.2 Identify Hazards	9
1.3.2.1 Task-Related Hazards	11
1.3.2.2 Working Near Power Lines	11
1.3.2.3 Power Line Visual Indicators	12
1.3.3 Assess Risks	13
1.3.4 Control Hazards to Reduce Risks	15
1.3.4.1 Personal Protective Equipment (PPE)	16
1.3.4.2 Control Strategies for Traffic	16
1.3.4.3 Control Strategies for Operating at Night or in Dark Areas	17
1.3.5 Report All Actions	17
1.4 Safety Equipment	18
1.4.1 Safety Harnesses	18
1.4.2 Lanyards and Energy Absorbers	18
1.4.3 Inspect Fall-Arrest Harness	19
1.5 Order Picking Forklift Trucks	20
1.5.1 Rear End Swing	21
1.5.2 Forklift Stability and Centre of Gravity	21
1.5.2.1 Centre of Gravity	21
1.5.2.2 Stability Triangle	22
1.5.2.3 Load Centre Distance	24
1.6 Getting from A to B	26
1.7 Communications	26
2.1 Pre-Start Checks	27
2.1.1 Visual Checks	27
2.1.2 Decals and Signage	28
2.1.3 Fluid Checks	28
2.1.4 Order Picker Controls	29
2.1.5 Safety Devices	29
2.1.6 Wheels/Tyres	30
2.1.7 Check Attachments	30
2.1.8 Logbook	30
2.2 Start the Order Picker	31
2.3 Operational Checks	31
2.4 Report Faults	31
2.5 Operate Order Picker	32
2.5.1 Applying Hazard Control Measures	32
2.5.1.1 Order Pickers and Pedestrians	33
2.5.2 Checking the Load	33
2.5.2.1 Calculating Load Weight	34
2.5.3 Picking Up a Load	38
2.5.4 Travelling with a Load	39
2.5.5 Placing a Load	40
2.6 Emergency Procedures	40
2.6.1 Lateral Instability	41
2.6.2 Longitudinal Instability	42

2.6.3 Order Picker Rollover Procedure	42
2.6.4 Order Picker Malfunction	43
2.7 Shut Down and Secure Order Picking Forklift Truck	43
2.7.1 Parking the Order Picker	43
2.8 Post-Operational Checks.....	44

1.1 Introduction

This training course is based on the National High Risk Licence Unit of Competence **TLILIC0004 Licence to Operate an Order Picking Forklift Truck**.

You will learn about:

- ◆ Planning out your work.
- ◆ Conducting routine checks on the order picking forklift.
- ◆ Operating the order picking forklift safely.
- ◆ Shutting down and securing the order picking forklift after use.



1.1.1 What is an Order Picking Forklift?

An order picking forklift is a powered industrial truck where the operator's controls are incorporated with the load carriage, and the operator elevates with it.



1.1.2 Parts of an Order Picking Forklift

It is important that you understand the different parts and controls of an order picking forklift. Below is a diagram outlining some important parts of an order picking forklift:

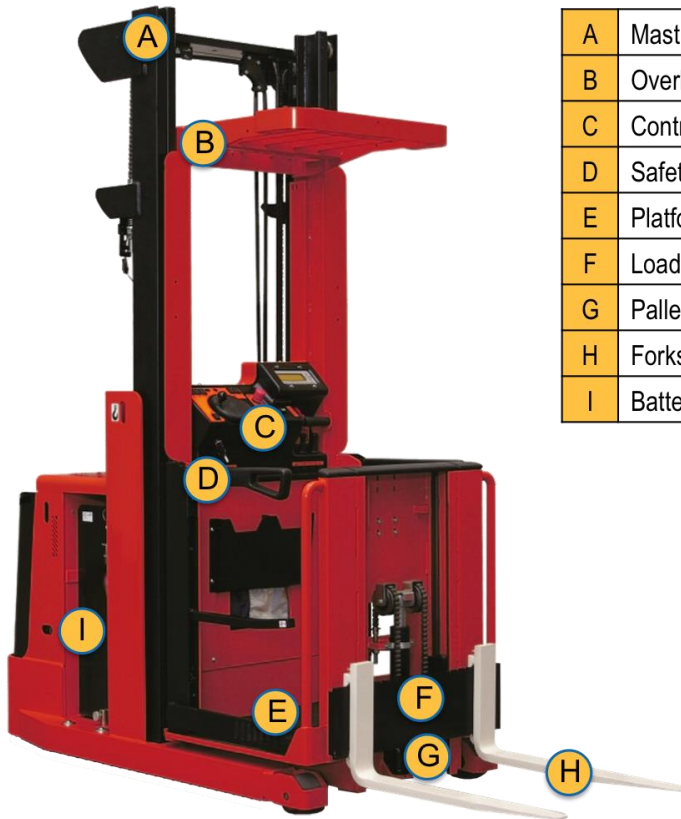

A	Mast assembly.
B	Overhead guard.
C	Controls & gauges.
D	Safety gate/barrier.
E	Platform & 'dead man' control.
F	Load backrest (not on all models).
G	Pallet grab.
H	Forks.
I	Battery/engine/motor.

1.1.3 High Risk Work Licence Requirements



Once you pass your assessment you will have **60 days** to apply for your licence.

You must renew your licence within 12 months of its expiry otherwise:

- ◆ Your licence can't be renewed.
- ◆ You need to repeat the course and re-apply for your licence.
- ◆ You need to enrol in the course again and be supervised by somebody who has a current licence for the same class.

You can still do high risk work without a licence as long as:

- ◆ You are enrolled in a high risk course for the class, and
- ◆ You are being supervised by somebody who has a licence for the same class.

Once you have obtained your High Risk Work Licence, prior to you undertaking work on an unfamiliar order picking forklift, your employer will provide:

- ◆ Information
- ◆ Training
- ◆ Instruction
- ◆ Supervision.

Any licensed worker must take reasonable steps to make sure the way they work does not impact on the safety of themselves or any other worker. **Failing to work safely can result in the health and safety regulator:**



- ◆ Suspending or cancelling your licence.
- ◆ Refusing to renew your licence.
- ◆ Ordering that you are reassessed to ensure you are competent.
- ◆ Directly reassessing you to determine your competency
- ◆ Taking legal action to prosecute you

Your employer might ask you for evidence that you have a high risk licence before you start any high risk work. You can show them:

- ◆ Your licence.
- ◆ Proof from the training company that you have passed your assessment.
- ◆ Proof that you are currently completing a course for high risk work.



1.2 Plan Work



It is important that you are aware of the requirements relating to your work. Before you begin your tasks ensure that you access the relevant documentation and plan your work.

Requirements relating to your work may include:

- ◆ WHS requirements.
- ◆ Duty of care.



1.2.1 Work Health and Safety Requirements

Work Health & Safety (WHS) laws and guidelines help keep your workplace safe.

These can be broken down into four main types:

Acts	Laws to protect the health, safety and welfare of people at work.
Regulations	Gives more details or information on particular parts of the Act.
Codes of Practice/Compliance code	Are practical instructions on how to meet the terms of the Law, e.g. Compliance Code: Plant.
Australian Standards	Give you the minimum levels of performance or quality for a hazard, work process or product, e.g. AS 2359.1:2019 Powered industrial trucks General requirements.

Sources of workplace safety information include, but are not limited to, the following:

- ◆ WHS/OHS policy
- ◆ Code of Practice/Compliance Code
- ◆ Manufacturer's instructions
- ◆ Operations manual
- ◆ Legislation and regulations
- ◆ Relevant Australian standards
- ◆ WHS/OHS workplace representative
- ◆ Safe working or job procedures
- ◆ Management plans

1.2.2 Duty of Care

All personnel have a legal responsibility under duty of care to do everything reasonably practicable to protect others from harm by complying with safe work practices, including activities that require licences, tickets or certificates of competency or any other relevant state and territory WHS requirements.

This includes:

- ◆ Employers and self-employed persons.
- ◆ Persons in control of the workplace.
- ◆ Supervisors.
- ◆ Designers.
- ◆ Manufacturers.
- ◆ Suppliers.
- ◆ Workers.
- ◆ Inspectors.



All workers, including an order picking forklift operator, have the following duty of care:

- ◆ Make sure they take reasonable care of their own health and safety
- ◆ Not put others in any danger (take reasonable care for the health and safety of others who may be affected by their acts or omissions)
- ◆ Cooperate with anything the employer does to comply with WHS/OHS requirements
- ◆ Not 'intentionally or recklessly interfere with or misuse' anything provided at the workplace for WHS/OHS.

Your employer must take steps to ensure that the workplace is as safe as possible for you and other workers. In order to do this, they must:



- ◆ Provide a safe workplace with minimal risks.
- ◆ Provide and maintain safe plant, equipment and structures.
- ◆ Provide and maintain safe systems/procedures for work.
- ◆ Provide facilities that are adequate for the personnel on site.
- ◆ Provide instruction, training, supervision and information for any work to be undertaken safely, including any time you are required to use an unfamiliar or new order picking forklift.
- ◆ Take action or make arrangements to ensure all equipment, structures, plant and substances used on site are handled and stored in a safe way.

1.3 Manage Hazards and Risks



Before starting any work it is important to manage any hazards or risks in the area, or related to the work.

A hazard is a thing or situation with the potential to cause harm or damage.

A risk is the chance of a hazard causing harm or damage. In other words, a risk is the possibility that harm (death, injury or illness) might occur when exposed to a hazard.

By lowering or removing risks we can make hazards less dangerous.

1.3.1 Consulting with Other Workers about Hazards and Risks

Controlling a hazard can be a team effort and it's important that everybody knows what they need to do and how or if they need to change their work process to suit.

Make sure you talk to the right people. This can include:

- ◆ **Safety officers.**
- ◆ **Site engineers (where applicable).**
- ◆ **Supervisors.**
- ◆ **Colleagues.**
- ◆ **Managers who are authorised to take responsibility for the workplace or operations.**
- ◆ **Health and Safety Representatives.**
- ◆ **Work Health and Safety Committee members.**

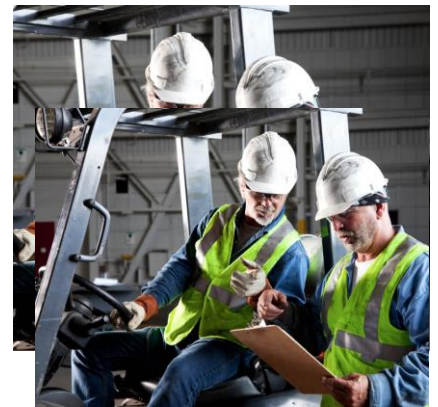

These people may have information about site hazards.

It is important to communicate with other personnel and safety officers before starting on a worksite:

- ◆ **To ensure that any workplace policies or site-specific procedures are followed.**
- ◆ **To identify (or be made aware of) any workplace-specific hazards/ground conditions**
- ◆ **To identify hazards and controls.**

1.3.2 Identify Hazards

Part of your job is to look around to see if you can find any hazards before you start any work.

Before you get started it's a good idea to check the path that you're planning to take with the order picking forklift, to make sure that you have identified all hazards in the path of movement and put effective control measures in place. This will help to make the workplace safer.

Check that the order picking forklift will fit and that there are no obstacles in the way. Also check for any other equipment or people working in the area.

Checking the weather forecast can help you to prepare for each day and allows you to:

- ◆ **Schedule your work activities**
- ◆ **Prepare risk controls associated with bad weather**
- ◆ **Plan out movements around the work environment.**

When you start checking for hazards, make sure you look everywhere. A good way to do this is to check:

- ◆ **Up high** above your head.
- ◆ All around you **at eye level**.
- ◆ **Down low** on the ground (also think about what is under the ground).

Some hazards you should check for in the work area:

- ◆ **Ground conditions:**
 - ◇ Condition of pavement and operating surface.
 - ◇ Non-weight bearing surfaces.
 - ◇ Wet or slippery surfaces.
 - ◇ Variable operating surfaces/routes e.g. slopes, ramps or other imperfections.
- ◆ **Overhead hazards:**
 - ◇ Power lines.
 - ◇ Overhead service lines.
- ◆ **Poor lighting.**
- ◆ **Surrounding structures:**
 - ◇ Buildings.
 - ◇ Obstructions.
 - ◇ Racking.
- ◆ **Traffic:**
 - ◇ Pedestrians.
 - ◇ Other workers.
 - ◇ Vehicles.
 - ◇ Other plant and equipment.
- ◆ **Weather:**
 - ◇ Wind.
 - ◇ Lightning.
 - ◇ Rain
 - ◇ Sun glare.
- ◆ **Order picker instability:**
 - ◇ Overloading.
 - ◇ Poor load placement.
 - ◇ Irregular loads.
- ◆ **Other hazards:**
 - ◇ Dangerous materials.
 - ◇ Falling from the order picker platform.
 - ◇ Worksite-specific hazards.

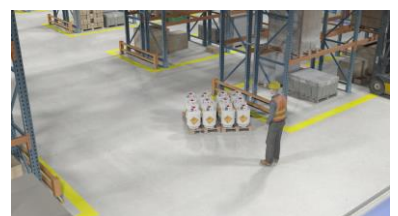

1.3.2.1 Task-Related Hazards

Some hazards may be caused by the way the work is done.

1.3.2.2 Working Near Power Lines

Working near power lines can be dangerous if you are not careful.

It is very important that you know the safe operating distances for different types of power lines and the steps you must take if your job needs you to work closer than the safe distances.

Generally, if you need to work closer than the safe work distance you must:

- ◆ Contact the local electrical authority for permission to work closer (this is called an exemption).
- ◆ Have the power lines shut off. If this is not possible then have the power lines insulated.
- ◆ Use a spotter (depending on local laws and rules).



Distances are different depending on the state or territory you are working in and the voltage of the power lines. **You should check with the local electrical authority** for information and advice to find out the voltage of power lines in your work area.

Victoria

In Victoria the Framework for Undertaking Work Near Overhead and Underground Assets states that equipment must not be closer than the following distances to electric/power lines:

Electric/Power Line Type	Distance
Distribution lines up to and including 66kV (power poles)	6.4m (or 3.0m with a qualified spotter)
Transmission lines greater than 66kV (towers)	10m (or 8m with a qualified spotter)

OR another way of thinking about it is:

- Pole 3.0 m with qualified spotter**
- Pole 6.4 m no spotter**
- Tower 8.0 m with qualified spotter**
- Tower 10 m no spotter**

1.3.2.3 Power Line Visual Indicators

There are a range of different indicators in use across the country to identify the position of overhead power lines.

Important: Visual indicators **DO NOT** insulate the power lines so exclusion zones and safe operating distances must still be used, even when any of these systems are in use.

Tiger Tails and Coloured Markers

Tiger tails or coloured markers are used to clearly show the location of overhead power lines.

Poles may also be coloured (painted) up to 3m from the ground.



Marker Balls or Flags

Marker balls are fixed to the power line and are often red or another bright colour.



Safety, Warning and Danger Signs

Signage may also be present to warn of overhead power lines and services.



Contact with Power Lines

If the order picking forklift truck makes contact with power lines you must:

1. Warn people to stay away.
2. Try to break contact with the power lines.
3. Stay in the order picking forklift if it is safe. Otherwise jump from the forklift without touching the forklift and the ground at the same time. Keep your feet together and jump or shuffle away from the forklift until you at least 8m away from it.
4. Report the incident to your supervisor, power company and safety regulator.
5. **DO NOT** use the forklift again until it has been checked and returned to service.



Managing other workplace hazards:

An order picking forklift truck operator must look for overhead hazards such as service pipes, doorways, roof beams, lights, fixed structures and obstacles or obstructions as part of inspecting the worksite before operations and when operating the order picking forklift truck near these hazards. This will help to avoid damage to the order picking forklift and load, injury to the operator and order picking forklift or load tip over.

When operating an order picking forklift on/around rough, uneven or difficult terrain such as cracked surface, potholes or backfilled ground and steel decks and grates:

- Tyres may be damaged that can cause instability of the order picking forklift
- The order picking forklift may tip over or lose load
- These surfaces not support the weight of the order picking forklift and the ground can be unpredictable.

1.3.3 Assess Risks

Once you have identified the hazards on site or related to the work you will be doing you need to assess their risk level. Risk levels are worked out by looking at 2 factors:

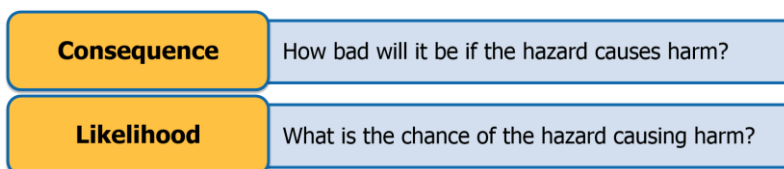

You can use a table like the one shown here to work out the risk level:

	Consequence				
Likelihood	1. Insignificant	2. Minor First Aid Required	3. Moderate Medical Attention and Time Off Work	4. Major Long Term Illness or Serious Injury	5. Catastrophic Kill or Cause Permanent Disability or Illness
1. Rare	Low	Low	Moderate	Moderate	Moderate
2. Unlikely	Low	Low	Moderate	Moderate	High
3. Possible	Low	Moderate	High	High	Extreme
4. Likely	Moderate	Moderate	High	High	Extreme
5. Almost Certain	Moderate	High	High	Extreme	Extreme

For example, a hazard that has a **Major** consequence and is **Almost Certain** to occur has a risk level of **Extreme**.

Likelihood	Consequence				
	1. Insignificant	2. Minor First Aid Required	3. Moderate Medical Attention and Time Off Work	4. Major Long Term Illness or Serious Injury	5. Catastrophic Kill or Cause Permanent Disability or Illness
1. Rare	Low	Low	Moderate	Moderate	Moderate
2. Unlikely	Low	Low	Moderate	Moderate	High
3. Possible	Low	Moderate	High	High	Extreme
4. Likely	Moderate	Moderate	High	High	Extreme
5. Almost Certain	Moderate	High	High	Extreme	Extreme

The risk level will help you to work out what kind of action needs to be taken, and how soon you need to act.

The table below is an example of a site risk policy:

Risk Level	Action
Extreme	This is an unacceptable risk level The task, process or activity must not proceed .
High	This is an unacceptable risk level The proposed activity can only proceed, provided that: <ol style="list-style-type: none"> 1. The risk level has been reduced to as low as reasonably practicable using the hierarchy of risk controls. 2. The risk controls must include those identified in legislation, Australian Standards, Codes of Practice etc. 3. The risk assessment has been reviewed and approved by the Supervisor. 4. A Safe Working Procedure or Work Method Statement has been prepared. The supervisor must review and document the effectiveness of the implemented risk controls.
Moderate	This is an unacceptable risk level The proposed activity can only proceed, provided that: <ol style="list-style-type: none"> 1. The risk level has been reduced to as low as reasonably practicable using the hierarchy of risk controls. 2. The risk assessment has been reviewed and approved by the Supervisor. 3. A Safe Working Procedure or Work Method Statement has been prepared.
Low	The proposed task or process needs to be managed by documented routine procedures, which must include application of the hierarchy of controls.

The action you take will depend on:

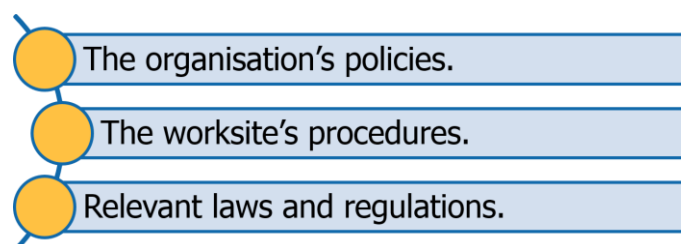

1.3.4 Control Hazards to Reduce Risks

The best way to control hazards is to use the Hierarchy of Hazard Control. The hierarchy of hazard control is a range of options that can eliminate, or reduce the risk level.

You start at the top of the list and see if you can take away (eliminate) the hazard or danger.

If you can't take it away you move down the list to see if you can swap it for something safer (substitution).

Keep working through the list until you find something (or a combination of things) that controls that hazard or danger.



This table shows you the six (6) different types of controls in order from best to worst:

Hierarchy Level	Action
1. Elimination	Completely remove the hazard. This is the best kind of hazard control.
2. Substitution	Swap a dangerous work method or situation for one that is less dangerous.
3. Isolation	Isolate or restrict access to the hazard. Includes using signage and barricades.
4. Engineering Controls	Use equipment to lower the risk level.
5. Administrative Controls	Site rules and policies attempt to control a hazard.
6. Personal Protective Equipment	The least effective control. Use PPE while you carry out your work.

It is important to think about all of the options available when deciding on the best hazard controls. You may need to use more than 1 control measure to bring the risk level down to an acceptable level.

When planning out the task, some things you may consider in addition to hazards are:

- ◆ **Characteristics of the load.**
- ◆ **Method of attachment.**
- ◆ **Adequate and safe communication techniques and equipment.**
- ◆ **Location and specific details of the task.**
- ◆ **Permits required for the task.**
- ◆ **Availability of equipment.**
- ◆ **Capacity of the order picking forklift.**
- ◆ **Blind spots – due to corners, the mast or the load.**

<p>Specifics of the task</p> <p>Permits for the task</p> <p>Access and Egress to the work area</p> <p>Capacity of the forklift</p> <p>Equipment required and Availability</p>
--



1.3.4.1 Personal Protective Equipment (PPE)

Personal Protective Equipment (PPE) is clothing and equipment designed to lower the chance of you being hurt on the job. It is required to enter most work sites.

You should select and inspect your PPE before you start work.

PPE includes:

- ◆ **Head protection** – hard hats and helmets.
- ◆ **Foot protection** – non-slip work boots.
- ◆ **Hand protection** – gloves.
- ◆ **Eye protection** – goggles, visors or glasses.
- ◆ **Ear protection** – plugs or muffs.
- ◆ **Breathing protection** – masks or respirators.
- ◆ **Hi-visibility clothing** – clothing that makes you stand out and lets other people know where you are.
- ◆ **Weather protection** – clothing that protects you from the sun or from the cold.

Make sure any PPE you are wearing is in good condition, fits well and is right for the job.

If you find any PPE that is not in good condition, tag it and remove it from service. Then tell your supervisor about the problem and they will organise to repair or replace the PPE.

1.3.4.2 Control Strategies for Traffic

If the work area is going to be shared with pedestrians, site personnel, vehicles or mobile plant, you will need to make sure you have control measures in place before you start.



These may include:

- ◆ **Using a flag person or traffic controller to control traffic.**
- ◆ **Setting up flashing hazard lights.**
- ◆ **Setting up warning signs and barriers.**
- ◆ **Setting up pedestrian and vehicle exclusion zones.**
- ◆ **Implementing a Traffic Management Plan.**

Implementing a traffic management plan that separates forklifts and pedestrians can decrease the likelihood of accidents and injuries caused by forklifts. It is the responsibility of employers and self-employed individuals to inform all individuals at the workplace, including employees, contractors, and visitors, about the forklift traffic management plan and provide proper training and instruction. The forklift traffic management plan should also be included in the workplace induction. All employees should be familiar with and trained in the plan. If a contractor or visitor who has not received training needs to cross a forklift route or enter a forklift working area, they must always be accompanied by someone who has been trained in the plan.

The area around the order picking forklift truck should be secured to prevent pedestrian access.

If it is not practical to fence off the work area from personnel other than the order picker operator you should use:

- ◆ Witches hats.
- ◆ Other personnel to assist.
- ◆ Flashing lights.
- ◆ Warning signs.



NEVER raise or lower the order picker platform near or over people's heads, as there is a risk of injury or death if the load or part of the load falls from the order picking forklift truck.

1.3.4.3 Control Strategies for Operating at Night or in Dark Areas



If order picker operations are being carried out at night or in darkened areas, adequate lighting needs to be provided across the entire work area.

This is to ensure that the order picking forklift operator and associated workers can see properly and carry out their work safely.

1.3.5 Report All Actions

It is important that you report the details of all identified hazards and all action taken to your supervisor.

Complete any forms required by site policies and procedures.

Speak with anybody who is affected by the actions you have taken to make sure they are aware of them, and know if they need to do anything differently.



1.4 Safety Equipment

It is important to use appropriate safety equipment when working at height. All safety equipment should be selected at the planning stage.

Safety equipment includes:

- Personal protective equipment relevant to site operations and requirements.
- Safety harness.
- Energy absorber.
- Lanyard.

The most important items of personal safety equipment that you must use while operating an order picking forklift are safety harness and lanyard.

1.4.1 Safety Harnesses

A safety harness is required to be worn at all times while operating the order picking forklift. It stops you from falling out of the order picker in the event of a collision or tip over.

Harnesses must be correctly fitted in accordance with the manufacturer's instructions to ensure effectiveness.

Workers should connect the fall-arrest line to the attachment point on their harness (dorsal attachment point in the middle of the back, or the chest connection) that will provide the best protection for the situation in which it is being used.



1.4.2 Lanyards and Energy Absorbers

There should be a minimum of slack in the fall-arrest lanyard between you and the anchor point, which should be as high as the equipment permits.

The length of the lanyard should restrict the fall distance to a maximum of 2 metres before the fall-arrest system takes effect.

To reduce injuries caused by a fall, energy absorbers should be used as part of the lanyard.



1.4.3 Inspect Fall-Arrest Harness



A fall-arrest harness must be inspected before use. Common defects that will condemn a harness from use are:

- ◆ Fraying.
- ◆ Splitting.
- ◆ Any obvious signs of damage to any part of the harness.

All harnesses and appropriate attachments need to be inspected in accordance with AS 1891. Shown here are some examples of things you need to check the harness for:

Component	Condition/Fault to be Checked
Webbing	<ul style="list-style-type: none"> ◆ Cuts or tears. ◆ Abrasion damage. ◆ Excessive stretching. ◆ Damage due to contact with heat, corrosives or solvents. ◆ Deterioration due to rotting, mildew, or ultraviolet exposure.
Snap Hooks	<ul style="list-style-type: none"> ◆ Distortion of hook or latch. ◆ Cracks or forging folds. ◆ Wear at swivels and latch pivot pin. ◆ Open rollers. ◆ Free movement of the latch over its full travel. ◆ Broken, weak or misplaced latch springs (compare if possible with a new snap hook). ◆ Free from dirt or other obstructions, e.g. rust.
D-rings	<ul style="list-style-type: none"> ◆ Excessive 'vertical' movement of the straight portion of the D-ring at its attachment point of the belt, so that the corners between the straight and curved sections of the D become completely exposed. <p>NOTE: Excessive vertical movements of the D-ring in its mounting can allow the nose of larger snap hooks to become lodged behind the straight portion of the D, in which position the snap hook can often accidentally 'roll out' of the D under load.</p> <ul style="list-style-type: none"> ◆ Cracks, especially at the intersection of the straight and curved portions. ◆ Distortion or other physical damage of the D-ring. ◆ Excessive loss of cross-section due to wear.
Buckles and Adjusters	<ul style="list-style-type: none"> ◆ Distortion or other physical damage. ◆ Cracks and forging laps where applicable. ◆ Bent tongues. ◆ Open rollers.
Stitching	<ul style="list-style-type: none"> ◆ Broken, cut or worn threads. ◆ Damage or weakening of threads due to contact with heat, corrosives, solvents or mildew.

1.5 Order Picking Forklift Trucks

Selecting the correct equipment for the job is very important.



Before starting the job you will need to think about:

- ◆ The ground conditions.
- ◆ How much room you have to work in.
- ◆ The height of loads that need to be accessed.
- ◆ The type of load and tasks to be performed.

These factors will influence your choice of order picking forklift truck.

Order picking forklifts are counter balanced. **By using the weight of the batteries, a load can be lifted safely without tipping the order picker forwards, i.e. batteries on an order picking forklift act as a counterweight.**

Never add additional counterweights to the order picker to increase its lifting capacity without referring to the manufacturer instructions first. This is extremely dangerous and may cause the order picker to become unstable.

The front wheels of the order picking forklift are where the point of balance (fulcrum) is located.

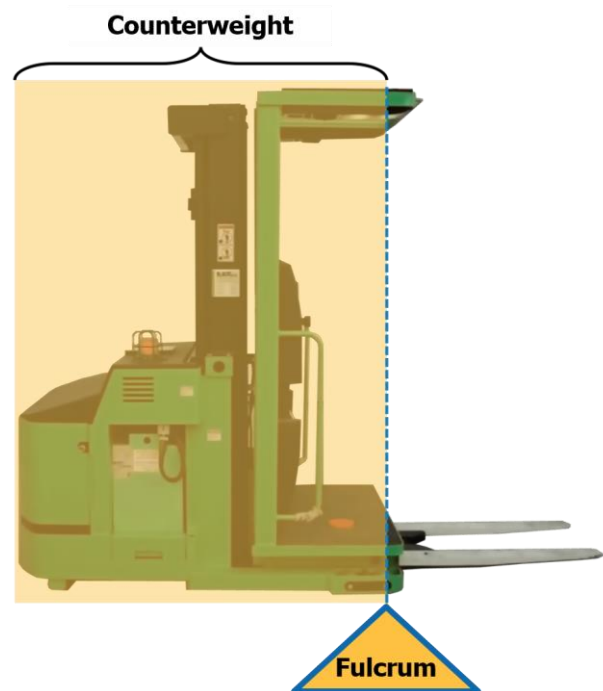

1.5.1 Rear End Swing

Rear end swing is the rapid sideways movement at the rear of the order picking forklift truck. This creates a risk of collision, particularly for pedestrians, plant or structures nearby.

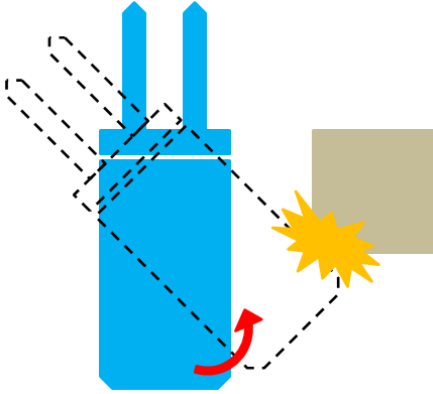

As order picking forklifts steer with the back wheels, the rear of the forklift turns up to three and a half times faster than the speed of travel.

With the rear end, steering operators need to keep to the inside of every turn to allow enough room for the rear of the order picker to swing around.

As soon as operators become careless about watching the swing, damage starts to occur. Most damage to stock, racking and machinery is caused by the rear of the order picking forklift hitting it.

A solution to this is to reinforce the dangers of rear end swing and to exclude pedestrian access from order picker operating areas.

1.5.2 Forklift Stability and Centre of Gravity

Stability is an important part in the safe operation of order picking forklifts. Some factors that affect the stability of the order picker are:

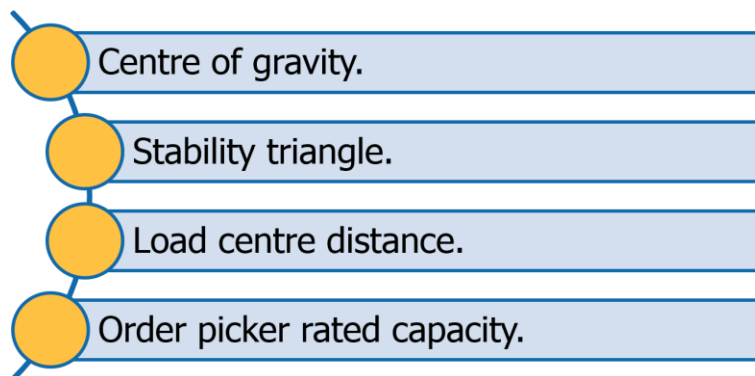

1.5.2.1 Centre of Gravity

The centre of gravity (CG) of any object is the single point about which the object is balanced in all directions. Every object has a CG.

The order picker has moving parts and therefore has a CG that moves. The CG moves forward and back as the mast is tilted forward and back. The CG moves up and down as the upright moves up and down.

When the order picking forklift picks up a load, the order picker and load have a new combined CG. The stability of the order picker is determined by the location of its CG, or if it is loaded, the combined CG.

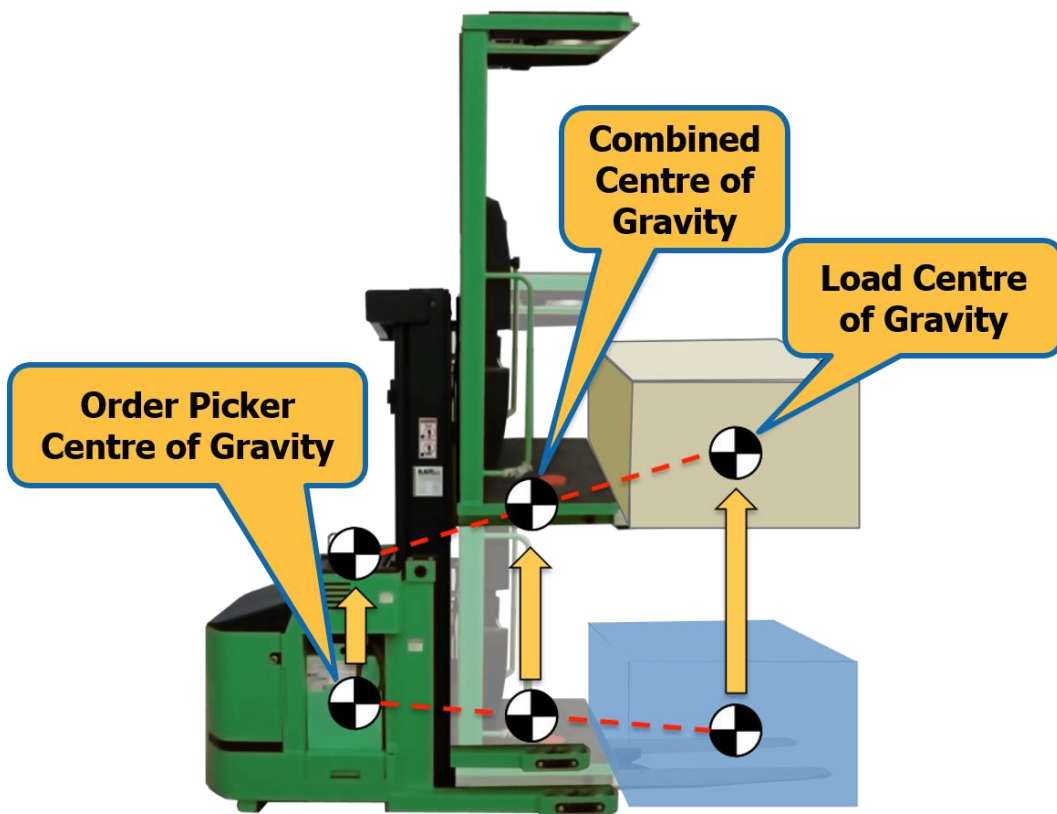

1.5.2.2 Stability Triangle

In order for the order picking forklift truck to be stable, the CG must stay within the area represented by a triangle drawn between the front wheels and the pivot of the steering axle. This area is called the stability triangle.

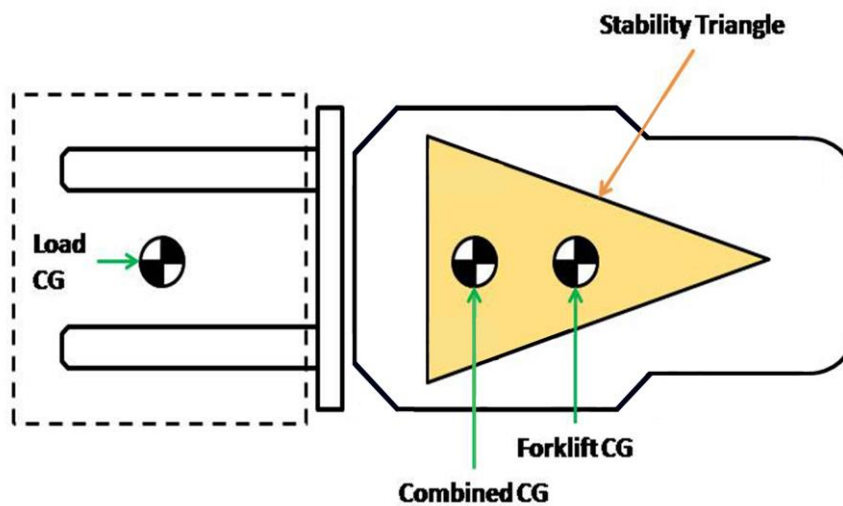

If the CG moves forward of the drive axle, the truck tends to tip forward (longitudinal). If the CG moves outside of the stability triangle, the truck tends to turn on its side (lateral).

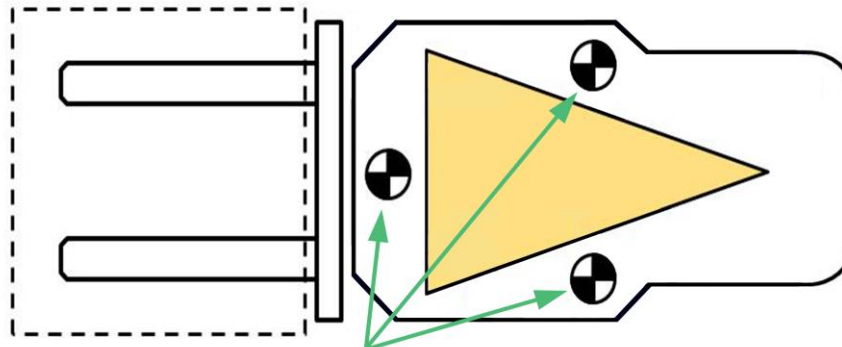

CG - Forklift will tip over

The centre of gravity, and therefore the stability, of the loaded truck is affected by a number of factors including size, weight, shape, and position of the load. Other factors are the height to which the load is elevated, tyre pressure, and the dynamic forces created when the truck is moving.

These dynamic forces are caused by things like acceleration, braking, operating on uneven surfaces or on an incline, and turning.

These factors must be considered when travelling with an unloaded order picking forklift as well, because an unloaded forklift will tip over to the side more easily than a loaded truck with its load in the lowered position.

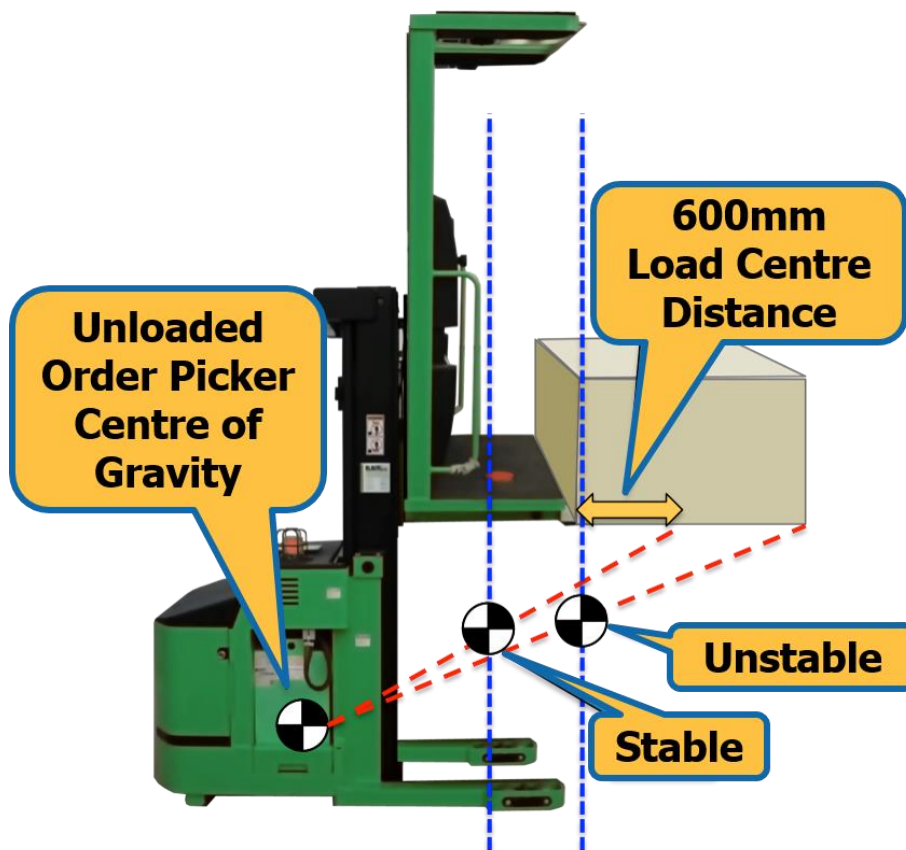

The centre of gravity of the order picker can move outside the stability triangle if:

- ◆ The load is picked up on the tip of the forks.
- ◆ The load is wide.
- ◆ Forklift movement causes the centre of gravity to shift.



1.5.2.3 Load Centre Distance

The distance from the vertical face of the loading platform to the centre gravity of the load is called the **Load Centre Distance**.

As load centre distance increases, the forklift's capacity decreases.

If the load is not hard up against the edge of the operator's platform, the order picker's rated capacity is reduced and stability may also be affected.

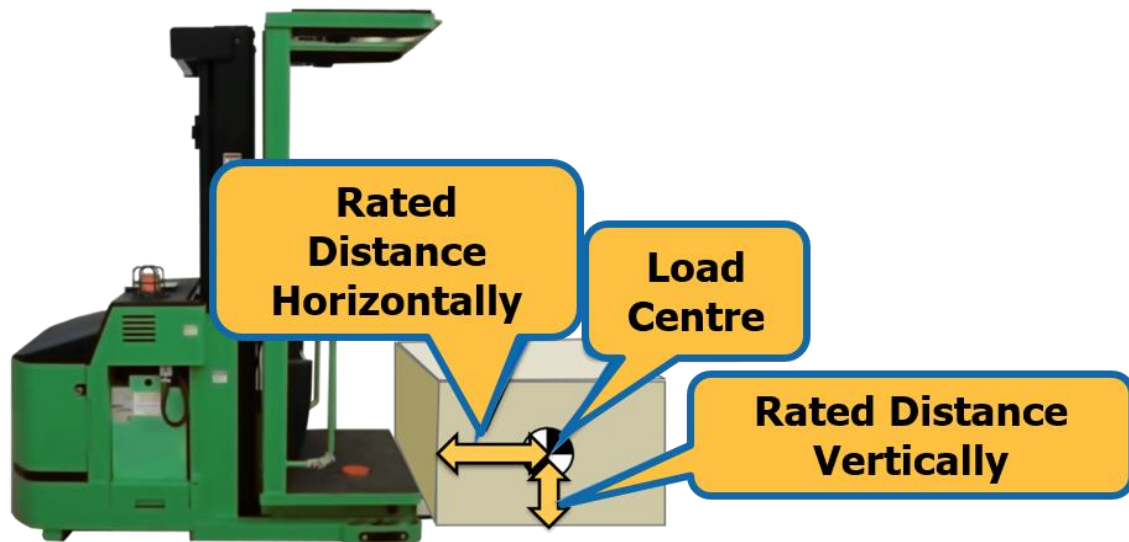

Always refer to the load chart/data plate of the order picker you are using for the rated capacity.

The rated capacity is the maximum load that an order picker is designed to carry at a load height and a specific load centre distance shown on the load chart.

As an example, each of the order picking forklifts shown here has a maximum load capacity of 1800kg. They are, however, rated at different load centres. The table below demonstrates which loads each of the order picking forklift trucks can legally and safely move:

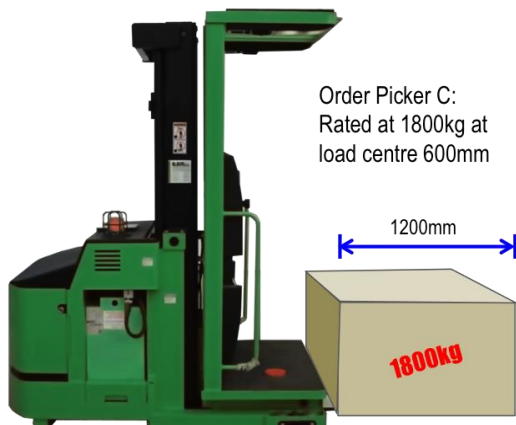
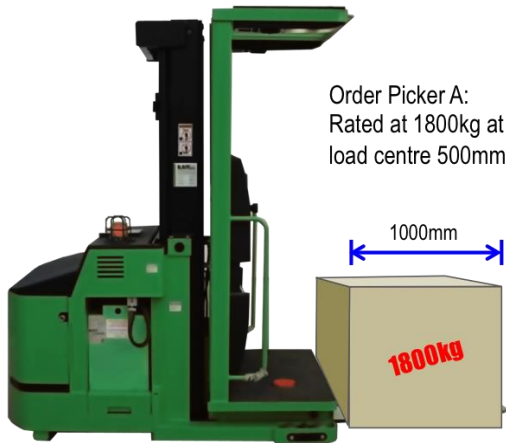

Load 1	Load 2	Load 3
Weight: 1600kg	Weight: 1750kg	Weight: 1800kg
Width: 1200mm	Width: 900mm	Width: 800mm
✗	✓	✓
✗	✗	✓
✓	✓	✓

1.6 Getting from A to B

Before you get started it's a good idea to check the path that you're intending to take to make sure that you have identified all hazards in the path of movement and implemented effective control measures.

Check that the order picker will fit and that there are no obstacles in the way. Also check for any other equipment or people working in the area.



1.7 Communications

As an order picker driver you need to be able to communicate with those around you while you work, and you need to be able to understand the instructions to use the forklift safely.

These can include:

- ◆ Manufacturer's guidelines (instructions, specifications, checklists).
- ◆ Industry operating procedures.
- ◆ Workplace procedures (work instructions, operating procedures, checklists).



Workplace communications may take the form of:

- ◆ Verbal (spoken) and non-verbal instructions.
- ◆ Written instructions and appropriate worksite protocol.
- ◆ Signs and symbols.
- ◆ Hand signals.
- ◆ Listening carefully and asking questions to check understanding and follow appropriate worksite protocols (rules).
- ◆ Maintaining eye contact.
- ◆ Using two-way radios.
- ◆ Pre-start meeting.

Situations in which you would use each of these communication procedures are given below.

- ◆ **Hand signals** – when operating an order picking forklift in a noisy environment; and when the order picking forklift operator's view of the intended path of travel is obstructed. **If a colleague gave you a hand signal when you were operating an order picking forklift which was unclear and confusing, you must stop operating the order picking forklift (stop all motions of the order picking forklift) and ask your co-worker to clarify the last hand signal they gave.**
- ◆ **Questioning techniques** – when clarifying work instructions with the Supervisor, clients or team members.
- ◆ **Signage** – to alert people to the presence of moving plant in a worksite; to isolate a work area in order to minimise risk of possible harm; to caution people about worksite requirements such as using correct PPE, access pathways/walkways etcetera.
- ◆ **Traffic warning systems** - as part of traffic management at the worksite, e.g. using cones, bollards, traffic lights and traffic signages.
- ◆ **Two-way radio** – can be used to instantly communicate with team members even when they are not in sight.
- ◆ **Written instructions** – can be used prior to commencing a task, e.g. referring to SWMS, worksite policies and procedures, order picking forklift operating manual etcetera; also, when completing order picking forklift logbooks or reporting maintenance requirements.

You must choose the appropriate communication methods at the planning stage OR before starting work.

2.1 Pre-Start Checks

Before you use the order picker you **MUST** check that it is safe to use.



Always use an inspection checklist when doing routine checks on the order picking forklift truck to make sure you check everything properly and so that you can report any problems that you find.

There are a number of areas that may need to be filled out, including:

- ◆ Company/machine/operator details.
- ◆ Order picker parts/operational checklist.
- ◆ Fault report.
- ◆ Maintenance report.
- ◆ Return to service signoff.

An example of a daily inspection checklist can be found in Appendix A.

2.1.1 Visual Checks

Before you do anything, walk around the order picker and check to see if there is any visible damage.

Visually check the order picking forklift for any damage or defects before and after using it.

Pre-start checks include, but are not limited to, the following

- ◆ Harness anchor points
- ◆ Battery (charged, water level, secured)
- ◆ Hydraulic fluid
- ◆ Wheel condition and secured
- ◆ Data plate(s)
- ◆ Security of attachments and locking devices
- ◆ All guards
- ◆ Mast
- ◆ Tynes/forks arms
- ◆ Warning devices
- ◆ Lights (if fitted)
- ◆ Gauges for damage.



2.1.2 Decals and Signage



Check that the order picker has the appropriate signage and labels.

This includes the data plate. Make sure you can read it clearly and that it is firmly attached to the forklift.

Do not use an order picker without a data/load plate!

If the order picker does not have a data/load plate, or you cannot read it, you must tag out the forklift and report the defect to an authorised person.

2.1.3 Fluid Checks

Check the following fluid levels (as appropriate to the order picker you are operating):

- Hydraulic oil.
- Engine oil.
- Transmission oil.
- Brake fluid.
- Cooling water.
- Battery electrolyte level in each cell.

2.1.4 Order Picker Controls

Check that you can find and identify the order picker controls. Check the operator's manual if you are unsure.



2.1.5 Safety Devices

Check that the order picker has the appropriate safety devices fitted. These can include:

- ◆ Lights:
 - ◇ Flashing amber light.
 - ◇ Head lights.
 - ◇ Brake lights.
 - ◇ Reverse lights.
- ◆ Guards:
 - ◇ Overhead guard (including attachment or anchor point for safety harness).
 - ◇ Safety gates and interlocks.
- ◆ Devices:
 - ◇ Emergency descend device (hydraulic release).
 - ◇ Dead man switch.
 - ◇ Reversing beepers.
 - ◇ **Pallet clamp/pallet locking device:**
In order to stop a pallet from moving on the fork tynes of an order picking forklift, make sure that the pallet locking device is activated or ensure the pallet grab device is engaged.
 - ◇ Sensors and safety switches to prevent the order picker from travelling whenever the platform is more than 600mm from the ground.



2.1.6 Wheels/Tyres



Check that the pressure of air-filled tyres is correct. This will help to maintain the stability of the order picker.

If the order picker is fitted with solid rubber tyres, **check that there are no large pieces of rubber missing, check the tyre is not worn down, make sure that any wear is even between the tyres, any damage to sidewalls and that the wheels are properly secured.**

2.1.7 Check Attachments

Make sure any attachments (including the forks) are securely fixed.

Check that modifications are approved and that attachments are fitted to the manufacturer's specifications (e.g. as per order picker or attachment data plate).

Do not use an order picker that has been modified beyond the manufacturer's recommendations.

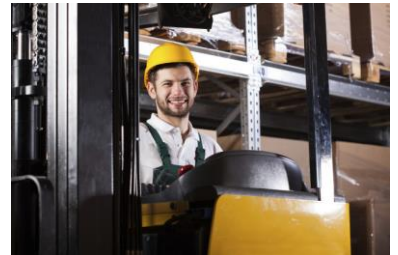

2.1.8 Logbook



Check for any previous faults with the order picking forklift. Make sure these faults have been fixed before using it.

2.2 Start the Order Picker



Once you have visually checked the order picker, start it as per the manufacturer's guidelines. Listen for any abnormal noises during start-up as these may indicate a fault.

Always wear your safety harness whenever you operate the order picker. It will help to protect you in the event of a fall.

2.3 Operational Checks

Operational checks are done once the order picker has been started. Operational checks include:

- ◆ Hazard warning systems (for example lights and horns) and gauges are functional.
- ◆ Battery charge level.
- ◆ All order picker movements and control functions are smooth and comply with operating requirements (e.g. dead man control).
- ◆ Steering, transmission and brake functions comply with operating requirements.

Check all movements and functions to their full extent to make sure the order picker is safe to operate.



2.4 Report Faults



If you find anything wrong with the order picker during your checks you must:

1. **Immediately stop the order picker and remove the keys.**
2. **Tag the order picker as out of service to stop anybody using it.**
3. **Record the problem in the logbook or on the inspection checklist. Give as much detail as possible.**
4. **Report the fault to your supervisor or other authorised person.**
5. **DO NOT operate the order picker until repairs are carried out.**

2.5 Operate Order Picker

The main function of an order picker is to allow the operator to travel up with or to the load and pack or unpack items.

At all times during operation you must follow safety procedures and workplace rules.

You must remain within the control platform at all times while operating the order picker.

The handrail on the platform (if fitted) must be closed at all times while the order picker is being operated.



Make sure you are secured to a purpose designed attachment/anchor point before stepping out onto the load platform.

2.5.1 Applying Hazard Control Measures

Once you are ready to use the order picker make sure you have implemented the required hazard control measures.

Talk to the other workers in the area to ensure they are aware of the work and the control measures you have put in place.

Control measures could include:



- ◆ Disconnecting power when working near power lines or overhead services.
- ◆ Putting safety tags on electrical switches/isolators to stop somebody from turning the power back on while you are working on or near power lines.
- ◆ Insulating power lines.
- ◆ Observing limits of approach during operation.
- ◆ Using a safety observer (also known as a spotter) inside the exclusion zone to make sure you don't get too close to power lines.
- ◆ Setting up barricades and traffic control to keep the area clear.
- ◆ Placing pedestrian controls (barricades, signs, etc.) to limit the number of people in the area.
- ◆ Moving any obstructions out of the way.
- ◆ Wearing Personal Protective Equipment (PPE) such as high-visibility clothing and non-slip work boots.
- ◆ Putting excavation safeguards such as barriers in place (where applicable).
- ◆ Setting up adequate lighting in the work area.

2.5.1.1 Order Pickers and Pedestrians

At any time order picking forklifts are being used in an area with pedestrian access, there should always be signs, barriers and designated pedestrian walkways.

If the area is not sectioned off and you are working at height you must lower the platform to as close as possible to the ground before traveling to the next section for your task.

All order picking forklifts should be fitted with safety flashing amber lights and horns.



Passengers may only be carried on the order picker if it has been designed and equipped to carry more than one person.

2.5.2 Checking the Load

Before you try to lift something, check that the order picker will be able to shift it safely.

Is the load within the rated capacity of the forklift? Check the load plate to make sure.

You can check the weight of a load in a number of ways:

- ◆ **Weigh the load.**
- ◆ **Check for markings on the load.**
- ◆ **Calculate the weight of the load.**
- ◆ **Check the weighbridge certificate.**
- ◆ **Check inventory systems**



Using labels/markings on the actual load paperwork such as consignment notes, running sheets and weighbridge dockets can help:

- ◆ to estimate or determine the weight and nature of the load, i.e. what is being lifted and what is its weight
- ◆ to determine whether weight of a load is appropriate for the order picking forklift truck and any attachment, if fitted



When using an attachment, always make sure you have factored in the weight of the attachment with your calculations.

Check the shape of the load. Make sure the heaviest part of the load is against the platform.

If the load is unstable, unevenly distributed or poorly stacked, restack it before you try to move it.

You may need to secure the load using shrink wrap or strapping/banding.

Check the pallet that the load is sitting on. If it is too damaged to lift, re-stack the load onto a new pallet.

Remember:

- ◆ If the load is too heavy – the order picking forklift may tip over.
- ◆ If the load doesn't fit on the tynes (irregular loads) – load is insecure and unstable which can result in tipping over of the order picking forklift or the load falling over.
- ◆ If you use an order picking forklift in a small and restricted area – there won't be sufficient space to operate the order picking forklift and injury from rear end swing of the order picking forklift may occur.

2.5.2.1 Calculating Load Weight

If you find you need to calculate the weight of a load, make sure you consider:

- ◆ How many items there are.
- ◆ What each item weighs.
- ◆ The weight of the pallet the items are placed on.



Example 1:

You need to move a load of cartons that have been stacked on a pallet.

- ◆ There are 4 cartons per layer and 6 layers on the pallet.
- ◆ Each carton weighs 33kg.
- ◆ The pallet is standard size and weighs 15kg.



To work out how much this load weighs you need to add the total weight of all of the cartons to the weight of the pallet:

Carton weight = 33kg x 4 (cartons) x 6 (layers)
Carton weight = 792kg

Total weight = 792kg + 15kg(pallet)
Total weight = 807kg

Example 2:



You need to move a load on a pallet that is made up of:

- ◆ 2 large boxes marked as 88kg each.
- ◆ 4 smaller boxes marked as 35kg each.
- ◆ The pallet is standard size and weighs 15kg.

To work out the weight of the load:

Weight = (Large boxes) + (Small boxes) + Pallet
Weight = (88kg x 2) + (35kg x 4) + 15kg
Weight = 176kg + 140kg + 15kg
Weight = 331kg

OR

Total weight =
88kg + 88kg + 35kg + 35kg + 35kg + 35kg + 15kg
Total weight = 331kg

Example 3:

You need to move a pallet loaded with 4 barrels of liquid.

- ◆ Each barrel weighs 210kg.
- ◆ The pallet weighs 22kg.



To work out the weight of the load:

Weight = (Barrel weight) + Pallet
Weight = (210kg x 4) + 22kg
Weight = 840kg + 22kg
Weight = 862kg

Read and understand the data plate given below. Then, refer to Examples 4, 5 and 6.

CAPACITY WITH MAST VERTICAL AND EQUIPPED AS SHOWN		
MAXIMUM CAPACITY	1360 kg (3000 lb)	kg (lb)
Load Height Dim. A	7010 mm (276 in)	mm (in)
Load Center Dim. B	610 mm (24 in)	mm (in)
Load Center Dim. C	610 mm (24 in)	mm (in)

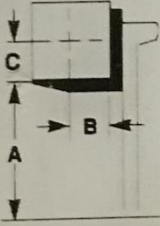

Serial Number
G118N01876A

Sales Order
903164

1460690

HYSTER

Lift Truck Model R30XM2

Attachment 1220 mm (48 in) Forks

Type E 36 Volts Max A.H. 1020

Truck Weight

Less Battery 2460 kg (5412 lb)

Max Battery 3480 kg (7612 lb)

Min Battery Wt. 770 kg (1700 lb)

Max Battery Wt. 1000 kg (2200 lb)

Base Width 1220 mm (48 in)

Wheel Base 1440 mm (57.0 in)

Trained Operators and Mechanics only

Read Operating Manual located on or near seat.

WARNING

Failure to follow operating, inspection, and maintenance instructions can cause serious injury or death!

Example 4:

The load to be moved is 1.1 metres long and weighs 1600 kg. The load is to be lifted to a height of 7 m. Is this load safe to lift?

No

Load centre = 1.1 metre / 2 = 550 mm. The load centre of the order picker is 610 mm. Hence, it is not overloaded. Lift height is 7 m which is within the lift height of the plant.

But, look at the load to be lifted i.e. 1600 kg. This is more than the vertical capacity of the order picker (maximum is 1360 kg).

Hence the load is not safe to be lifted.

Example 5:

The load to be moved is 1.1 metres long and weighs 1300 kg. The load is to be lifted to a height of 7.5 m. Is this load safe to lift?

No

Load centre = 1.1 metre / 2 = 550 mm. The load centre of the order picker is 610 mm. Hence, it is not overloaded. Load to be lifted is 1300 kg which is within the weight capacity of the plant.

But, look at the height to which this load is to be lifted i.e. 7.5 m. This is more than the maximum lift height of the plant. Hence the load is not safe to be lifted.

Example 6:

The load to be moved is 1.1 metres long and weighs 1350 kg. The load is to be lifted to a height of 5.5 m. Is this load safe to lift?

Yes

Load centre = $1.1 \text{ metre} / 2 = 550 \text{ mm}$. The load centre of the order picker is 610 mm. Hence, it is not overloaded.

Lift height is 5.5 m which is within the lift height of the plant.

Load to be lifted is 1350 kg which is within the weight capacity of the plant.

Hence, the load is safe to be lifted.

2.5.3 Picking Up a Load

When picking up a load with the forklift ensure that you:

- 1 Approach the load squarely.**
- 2 Insert the forks all the way into the pallet.**
- 3 Raise the forks.**
- 4 Use the pallet clamp/pallet locking device to secure the pallet (if fitted). This will prevent the pallet from moving on the fork tines.**
- 5 Keep the load low for safe travel.**

DO NOT carry the load on only one fork arm. If you do the stability of the order picker may be affected, and you may cause damage to the forklift.

Make sure the warning devices are working correctly and always look over both shoulders before reversing in the order picker.

If possible (depending on the location of the controls on the order picker) face the direction of travel and make sure that all warning devices are working properly to warn other personnel who are nearby.



2.5.4 Travelling with a Load



Never travel the order picker while you are raised more than 600mm from the ground. Order picking forklifts may be fitted with sensors or safety switches to prevent the order picker from travelling while raised. **Under no circumstances should you tamper with or interfere with these safety features to allow the order picker to travel while raised.** They are fitted for a reason – to keep the order picker stable.

Always lower the load as close to the ground as possible while travelling for stability. Under 600mm is considered a safe height for traveling with a load on an order picking forklift.

Sound your horn before lowering the order picker or traveling while raised.

If the load blocks your view:

- ◆ **Drive forward if possible**
- ◆ **Check that the pathway is clear.**
- ◆ **Look over both shoulders if reversing.**
- ◆ **Repack the load if possible.**
- ◆ **Use warning devices such as a horn and flashing lights.**
- ◆ **Get somebody to direct you and keep an eye out for other people or equipment in the area.**



Be aware of rear end swing. This can be very dangerous for people nearby. Keep to the left of aisles and roadways for two-way traffic and maintain a safe distance from other vehicles at all times.



Maintain a safe operating speed based on:

- ◆ The size and type of the load.
 - ◆ Worksite policies, procedures and signage.
 - ◆ Weather conditions.
 - ◆ Ground/floor conditions. **If the floor is wet or slippery you should reduce your speed, avoid using ramps or other inclined pathways and proceed with caution.**
 - ◆ Personnel and other equipment in the area.
- ◆ Forklift technical limitations and capabilities.

You need to constantly monitor the load movement to ensure that personnel in the area are safe, and that the load and order picker are stable.

Avoid traveling on slopes, ramps or inclines. Order picking forklifts are top-heavy and more likely to overturn on an inclined surface.

Stick to hard level surfaces while traveling in the order picker.



If loading onto a truck from a loading dock, make sure there are secured dock plates or bridge plates in place.

Under no circumstances are you permitted to leave one rack and turn into another while the platform is elevated as the order picker could overturn. Always lower the platform first.

Remember:

- **when operating an order picking forklift on a slippery surface (e.g. water/oil/ice impacted surfaces):** it may slip, lose stability and tip over. It may also cause the load to fall over.
- **when operating an order picking forklift on soggy ground:** The ground can be unpredictable and may not support the weight of the order picking forklift truck. The truck or the load may fall over.
- **when operating an order picking forklift in heavy winds:** the order picking forklift may tip over or the wind may cause the load to fall over. The wind may also disturb the operator. Winds can cause a person's eyes to lose their natural moisture and become dry. They may also be irritated by dust and dirt in the air.
- **when operating an order picking forklift in sun glare:** Sun glare may impair the operator's visibility.

When operating an order picking forklift in heavy winds:

- Use PPE appropriate for the weather conditions, e.g. goggle, hat, earmuffs
- Assess risks and monitor the safety and stability of the load
- Operate the order picking forklift only if safe to do so
- Stop and notify the supervisor if/when the situation worsens
- Reassess the weather conditions prior to resuming order picking forklift operations

When operating an order picking forklift in sun glare:

- Wear sunglasses
- Drive slowly
- Look for an alternative route free from sun glare
- Wait for the environmental conditions to be favourable, if possible

2.5.5 Placing a Load

When placing a load using an order picking forklift truck, make sure that you:

1. Approach the load destination slowly.
2. Lower the load.
3. Disengage the pallet locking device (if fitted).
4. Reverse the order picker to remove the forks, making sure you don't scrape the forks on the pallet.

If refilling stock into racking or shelves, you need to make sure that:

- ◆ **The racking or shelves are suitable for the weight:**
- ◆ **Loads are stacked on a firm level surface.**
- ◆ **Heavy goods are placed at the bottom.**
- ◆ **The stock does not become unstable due to height.**



2.6 Emergency Procedures

If something goes wrong while you are using the order picking forklift it is important that you have an idea of what to do.



In the case of any workplace emergency you must make sure that you:

- ◆ Communicate where the emergency is located
- ◆ Inform workers of safe and unsafe areas.
- ◆ Provide information to emergency services, co-workers, supervisors and first aiders.

It is important that you give right of way to all emergency vehicles during emergency situations.

2.6.1 Lateral Instability

Conditions that may cause an order picking forklift truck to tip over sideways (lateral instability) include:

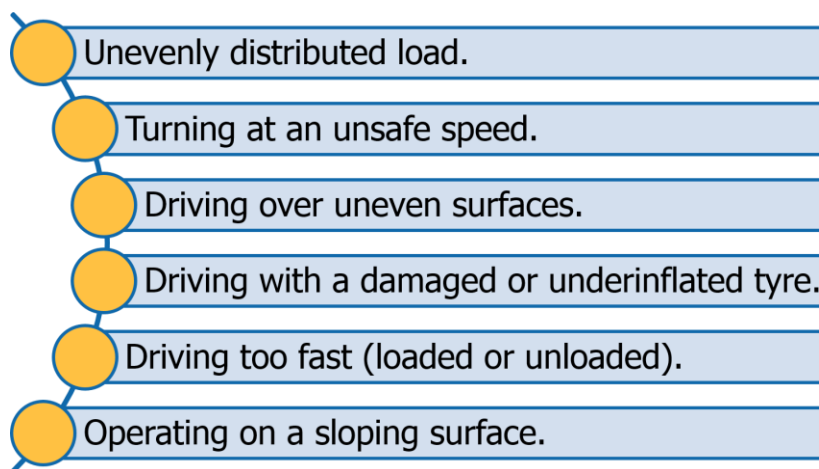

2.6.2 Longitudinal Instability

Conditions that may cause an order picking forklift truck to tip forward lengthways (longitudinal instability) include:

- ◆ **Overloading.**
- ◆ **Severe braking.**
- ◆ **Unevenly distributed load.**
- ◆ **Shifting of the load centre forward (centre of load is forward of the approved load centre).**
- ◆ **Operating on sloping surface.**
- ◆ **Load not positioned properly against the platform.**
- ◆ **Driving too fast (loaded or unloaded), including reversing.**
- ◆ **Making contact with overhead obstacles like rafters or pipes.**

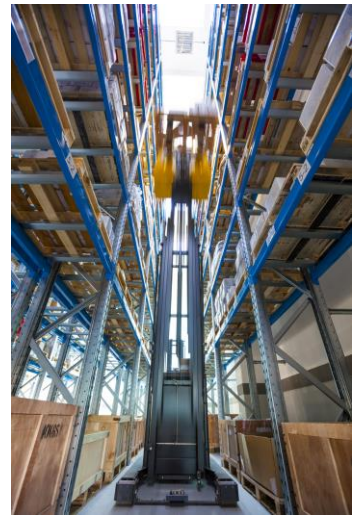

2.6.3 Order Picker Rollover Procedure

If you lose control of the order picker and it begins to tip sideways:

1. Remain in the order picker.
2. Brace yourself until the order picker is stationary and is safe to exit.
3. **DO NOT** try to jump from the order picker while it is tipping over.



If using a turret truck type forklift where the controls are operated from a seated position it is important that you wear the seat belt. It will prevent you from falling out in the event of a rollover and in the event of a collision it prevents the operator from being propelled into the forklift structure or out of the forklift.

2.6.4 Order Picker Malfunction

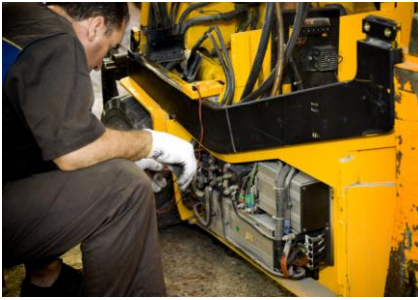

If the platform drops suddenly, or you suspect there is a problem with the brakes, steering or hydraulic system, immediately lower the load and turn off the order picker.

Check the order picking forklift for any signs of damage or wear and check hydraulic lines for splits or bulges.

Report the fault to an authorised person.

When operating an order picker, if there is an issue or defect with the engine, brakes and steering or equipment you use, the following could happen:

- Possible accidents
- Injury to people
- Unstable plant
- Not able to complete required order picking forklift task

2.7 Shut Down and Secure Order Picking Forklift Truck



When you have finished using the order picker, you need to park it, shut it down, remove the keys and conduct post-operational checks.

2.7.1 Parking the Order Picker

Always park the order picking forklift on a flat surface out of the way of other traffic.

DO NOT park the order picking forklift:

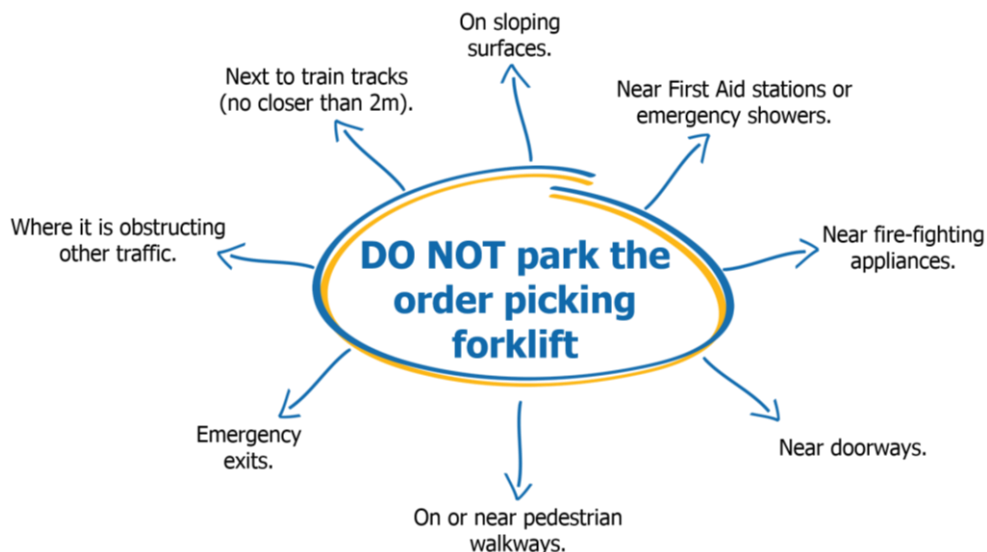



When parking the order picking forklift, normal parking procedures are:

- ◆ Make sure the fork arms are correctly lowered.
- ◆ Select an appropriate transmission/gear (neutral) and apply the appropriate brakes and motion locks.
- ◆ Turn the engine off and remove the keys from the ignition to prevent unauthorised use and movement of the order picker (if applicable).
- ◆ Any other site-specific safety procedures as required to shut down and secure the order picker. You may also refer to the manufacturer's instructions or operator's manual for details of how to properly shut down the order picker.

If you have to park the order picker on an incline, make sure you also chock the front wheels in addition to normal parking procedures.

2.8 Post-Operational Checks

After you have finished using the forklift, you need to check it to make sure it is ready for the next operator.



Attach batteries to a charger if applicable. **When under charge, batteries give off explosive gases and they must be expelled from the work area to avoid an explosion.**

Always charge batteries in a well-ventilated area away from any naked flame as during charging hydrogen gas can be generated, build up and combust

Do not smoke around a charging battery –the fumes could ignite, causing an explosion or a fire.

If you are connecting and disconnecting an electric battery from the transformer (power source) and/or the order picking forklift truck:

- ◆ Turn power off first before connecting to and disconnecting from the transformer
- ◆ Check all connections
- ◆ Turn on power after reconnecting
- ◆ Ensure nobody accesses the order picker when the battery is on charge
- ◆ Make sure the batteries are topped up with water, as required
- ◆ Perform operational checks once the battery is reconnected to the order picking forklift truck before operating the truck.

If you find any fault with the order picker when operating it:

1. Stop any operation and remove the keys.
2. Tag the order picking forklift – put a danger tag on the order picking forklift to stop anybody using it.
3. Record the problem in the logbook or on the inspection checklist. Give as much detail as possible.
4. Report the fault to an authorised person.

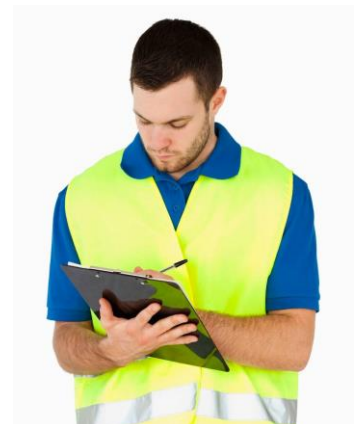

You may make minor repairs to the order picking forklift if you are competent and authorised to do so.